



EFL703-HV-6

HIGH CAPACITY ELECTRIC COUNTERBALANCED FORKLIFT 7.0T

 7000 kg  7000 mm  309 V Li-Ion



The EFL503–703HV Series is purpose-built for industries that demand strength, reliability, and safety in extreme working conditions — such as steel production, construction materials, ports, and heavy logistics. Its dual-wheel front axle enhances traction and balance when transporting bulky materials on uneven or slippery ground. With its fast 1C charging capability and long battery life (up to 4000 cycles), it is the ideal solution for multi-shift operations that require continuous power and minimal downtime.

SPECIFICATION	REF	UNIT	VALUE
Battery type			Li-Ion
Battery nominal capacity		Ah	228
Battery voltage		V	309
Load capacity	Q	kg	7000
Load centre distance	c	mm	608.5
Service weight		kg	9950
Retracted mast height	h_1	mm	2480
Lift height	h_3	mm	3000
Height, mast extended	h_4	mm	4470/3965
Overall length		mm	4775
Overall width	b_1/b_2	mm	2028
Length to face of forks	l2	mm	3555
Fork dimensions	s/e/l	mm	60×150×1220
Turning radius		Wa	3255
Operator type			Seated
Load distance, centre of drive axle to fork		mm	600

Features

High Performance: High speed and high gradeability

High-voltage Li-ion batteries enable more power delivery to motors, improving acceleration and travel speeds for high-capacity trucks. PMSMs complement this with rapid response times, swiftly reaching required speeds and torques. This combination of PMSM and high voltage can provide stable and strong power output, which further gives high-capacity trucks excellent climbing capabilities ensuring that the forklift can cope with various applications with ease.

The high-voltage model offers a 1.5-2 times performance improvement over the low-voltage model. Taking the 10-ton model as an example:

100% improvement in travel speed for high voltage models in laden and unladen conditions.

The high-voltage model demonstrates a 45% faster lifting speed.

100% improvement in gradeability when unladen, 45% improvement when laden for high voltage models.

Energy Efficiency: extended runtime and fast charging

High-voltage Li-ion batteries have high energy density and can store more electrical energy within a compact volume. High-voltage systems consume less energy and provide longer battery running time comparing low-voltage systems. Notably, these high-voltage Li-ion batteries boast an impressive cycle life of up to 4000 cycles, ensuring long-term durability and minimizing the need for battery replacements.

The PMSMs incorporate advanced control technology to optimize motor efficiency. Unlike traditional AC motors, PMSMs have higher energy conversion efficiency and reduce energy waste. This means that high-capacity trucks can work continuously for prolonged hours at lower costs.

Equipped with fast charging capabilities, high-capacity trucks offer a remarkable charging experience. The high-voltage models are compatible with vehicle-grade charging stations and support 1C charging rating, allowing them to be fully charged in as fast as 1-1.2 hours. This minimizes downtime and maximizes productivity, making it ideal for multi-shift operations

Lithium batteries present considerably lower charging costs than fuel expenses. The integration of high-voltage and PMSM technology achieves up to 15% greater electricity savings versus traditional lithium and AC technology configurations. This significantly reduces long-term energy consumption costs.



Safety Assured: Battery, motor protection, monitoring and mast buffering

Both high-voltage lithium batteries and PMSM employ multiple protective measures to ensure safe operations including overcharge protection, over-temperature monitoring, short-circuit protection, etc. minimizing the risk of potential hazards and maximizing operational safety.

The central controlling module- VCU (Vehicle Control Unit) extends the safety of the high-voltage forklifts. VCU provides precise control and real-time monitoring of critical parameters to ensure the truck operates within safe limits.

It also features turn speed control, which adjusts the forklift's speed based on the turning angle, ensuring stability during turns. An over-speed alarm alerts the operator if the forklift exceeds the safe speed limit.*

The high-capacity forklift mast is equipped with a hydraulic buffering system that ensures smooth lifting and lowering of loads. With controlled deceleration, the fork movement is smooth with no abrupt stops that could damage the load or cause operator discomfort. This feature enhances operational safety and prolongs the lifespan of the mast components.



Low maintenance: Longer battery life span

Operating at a higher voltage allows the battery to be designed with fewer individual cells. With fewer components and a simpler design, the risk of battery failure is lowered.

Thanks to advanced BMS (Battery Management System) which helps to regulate and monitor high-voltage battery, these batteries tend to have a longer life than low-voltage lithium batteries, reducing the need of battery replacement.

The brushless, simple rotor design of PMSM eliminates mechanical wear from brushes and commutators. This durable, low-friction construction requires minimal periodic maintenance, reducing associated labor costs and downtime.

Strong adaptability adaptable to harsh outdoor weather conditions

Experience uninterrupted productivity through rain, puddles, and damp conditions with the overall IPX4 rating. Plus an exceptional IP67 rating for high-voltage components. Engineered to withstand harsh temperature, high-capacity trucks offer an ambient temperature range of -20 °C ~40 °C allowing them to perform no matter climate.

Battery heating when charging comes as a standard function for high capacity models, which is activated when the surrounding temperature is below zero to always offer an optimal temperature range for efficient and safe charging even in cold weather conditions.

The dual front wheels is a standard configuration on several models offering a wider base of support, which greatly improves the forklift's stability. Considering the capacity loads of the high-capacity trucks, the weight of the load is more evenly distributed across a larger surface area. The increased ground contact area provided by the dual wheels enhances traction. This is particularly beneficial in environments where the floor may be slippery or uneven while operating outdoors, ensuring that the forklift can maintain a firm grip and operate safely. This not only helps in maintaining balance but also minimizes the stress on individual tires, extending the lifespan of the tires.



VDI Chart

	SPECIFICATION	REF	UNIT	VALUE
1.4	Operator type			Seated
1.5	Load capacity	Q	kg	7000
1.6	Load centre distance	c	mm	608.5
1.8	Load distance, centre of drive axle to fork		mm	600
1.9	Wheelbase		mm	2300
2.1	Service weight		kg	9950
2.2	Axle loading, laden front/rear		kg	15200/1750
2.3	Axle loading, unladen front/rear		kg	4515/5435
3.1	Tyre type			Pneumatic
3.2	Tyre size, front		mm	8.25-15-14PR
3.3	Tyre size, rear		mm	8.25-15-14PR

SPECIFICATION		REF	UNIT	VALUE
3.5	Wheels, number front/rear (x=drive wheels)			4x/2
3.6.1	Tread width, front	b ₁₀	mm	1498
3.7.1	Tread width, rear	b ₁₁	mm	1718
4.0	Max lift height	H	mm	7000
4.1	Tilt of mast/fork carriage forward/backward		°	6/12
4.12	Tow coupling height		mm	600
4.13	Loading height, unladen			2480
4.15	Lowered height			4470
4.16	Length of loading surface			4775
4.17	Overhang			0
4.19	Overall length		mm	4775
4.2	Retracted mast height	h ₁	mm	2480
4.2.1	Overall height			4470
4.20	Length to face of forks	l ₂	mm	3555
4.21	Overall width	b ₁ /b ₂	mm	2028
4.22	Fork dimensions	s/e/l	mm	60×150×1220
4.23	A,B Fork carriage class/type A, B			4A
4.24	Fork carriage width		mm	1845 (1995)
4.25	Distance between fork-arms			608.5
4.3	Free lift		mm	165
4.31	Ground clearance, laden, below mast		mm	160
4.32	Ground clearance, centre of wheelbase		mm	265
4.34.1	Aisle width for pallets 1000×1200 crossways		Ast	5265
4.34.2	Aisle width for pallets 800×1200 lengthways		Ast	5265
4.35	Turning radius		Wa	3255
4.4	Lift height	h ₃	mm	3000
4.5	Height, mast extended	h ₄	mm	4470/3965
4.7	Height of overhead guard (cabin)		mm	2590
4.8	Seat height/standing height		mm	1490
4.9	Height of tiller handle in drive position min./max.			1490
5.1	Travel speed, laden/unladen		km/h	25/26
5.10	Service brake			Hydraulic
5.11	Parking brake			Mechanical
5.2	Lifting speed, laden/unladen		m/s	0.51/0.53

SPECIFICATION	REF	UNIT	VALUE
5.3	Lowering speed, laden/unladen	m/s	0.48/0.42
5.8	Max. gradeability, laden/unladen	%	30/30
6.1	Drive motor rating S2 60 min	kW	60
6.2	Lift motor rating at S3 15%	kW	2x27.8
6.4	Battery nominal capacity	Ah	228
6.4	Battery voltage	V	309
6.4.1	Battery type		Li-Ion
6.5	Battery weight	kg	693
8.1	Type of drive control		PMSM
10.5	Steering design		Hydraulic
10.7	Sound pressure level at the drivers ear	dB(A)	/

VDI Drawing

EFL703-HV-6
RATED CAPACITIES AND LOAD CENTERES GRAPH

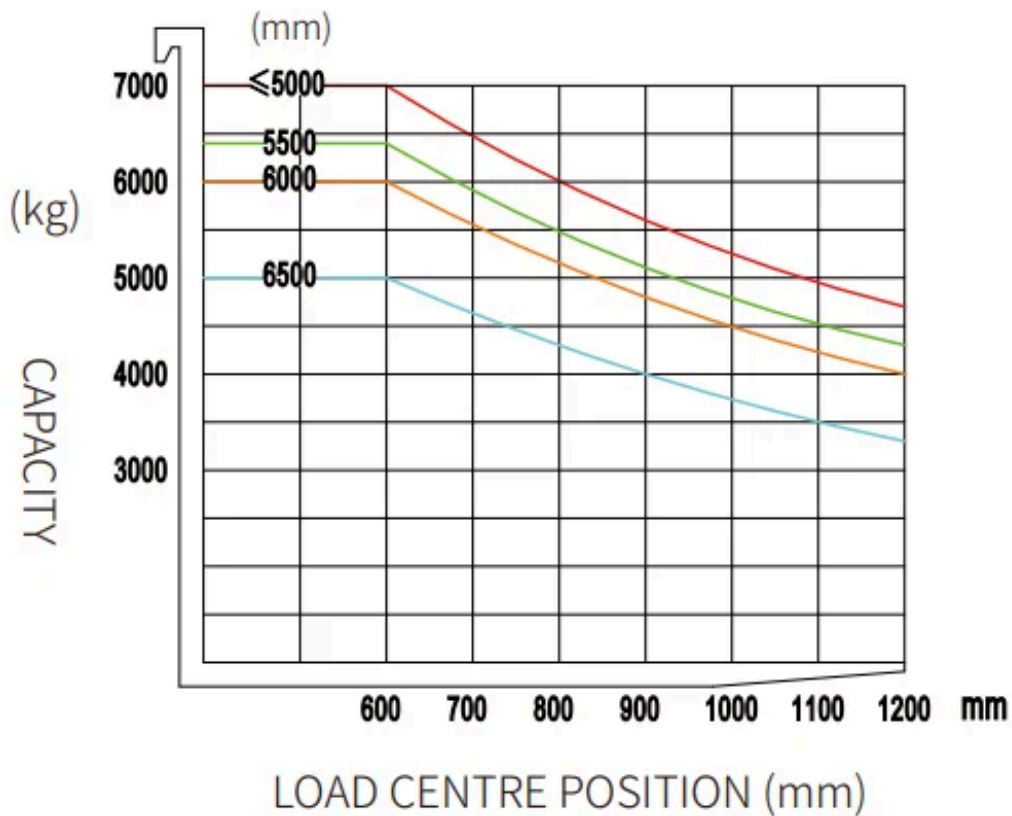

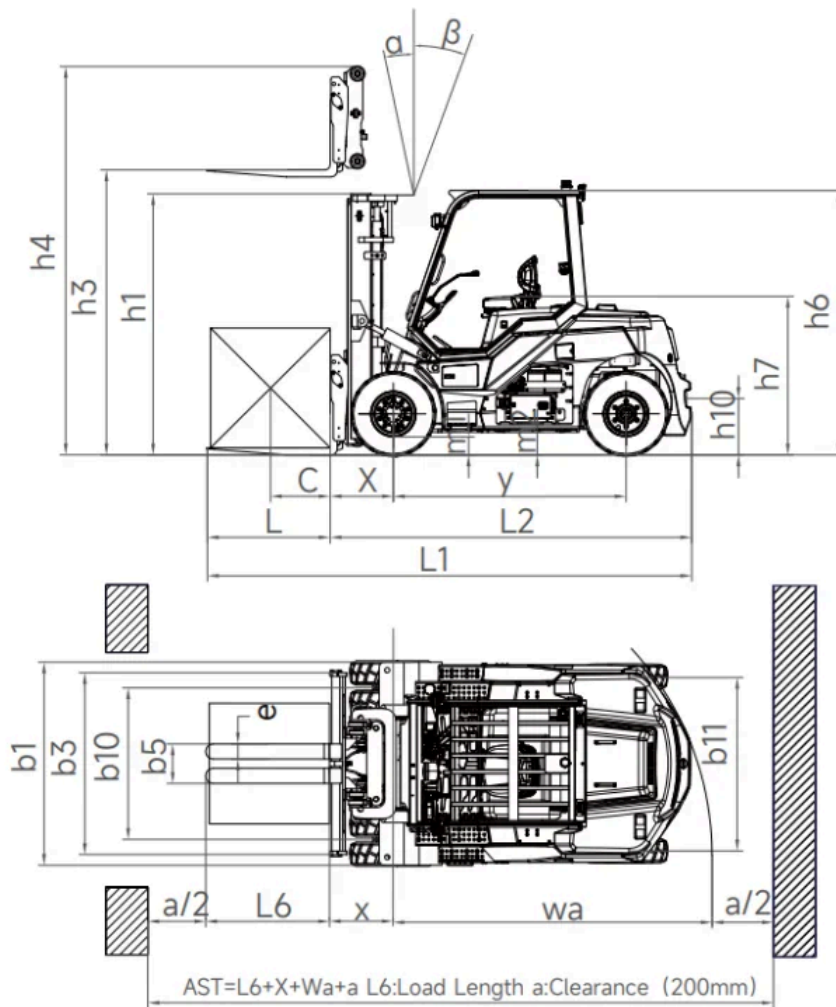

Mast Options

MAST TYPE	LIFT HEIGHT (H3, MM)	MAST LOWERED HEIGHT (H1, MM)	MAST EXTENDED HEIGHT, NO BACKREST (H4, MM)	MAST EXTENDED HEIGHT, WITH BACKREST (H4, MM)	FREE LIFT HEIGHT, NO BACKREST (H2, MM)	FREE LIFT HEIGHT, WITH BACKREST (H2, MM)
2-Standard Mast	3000	2480	3960	4470	165	165
2-Standard Mast	3500	2730	4460	4970	165	165
2-Standard Mast	4000	2980	4960	5470	165	165
2-Standard Mast	4500	3280	5460	5970	165	165
2-Standard Mast	5000	3530	5960	6470	165	165
2-Standard Mast	5500	3830	6460	7470	165	165
2-Standard Mast	6000	4080	6960	7470	165	165
2-Standard Mast	6500	4380	7460	7970	165	165
2-Free Mast	3000	2480	4310	4470	1400	1318

MAST TYPE	LIFT HEIGHT (H3, MM)	MAST LOWERED HEIGHT (H1, MM)	MAST EXTENDED HEIGHT, NO BACKREST (H4, MM)	MAST EXTENDED HEIGHT, WITH BACKREST (H4, MM)	FREE LIFT HEIGHT, NO BACKREST (H2, MM)	FREE LIFT HEIGHT, WITH BACKREST (H2, MM)
2-Free Mast	3500	2730	4810	4970	1705	1585
2-Free Mast	4000	2980	5310	5470	2000	1818
3-Free Mast	4500	2660	5636	5976	1565	1225
3-Free Mast	4800	2760	5936	6276	1665	1325
3-Free Mast	5000	2810	6086	6476	1765	1375
3-Free Mast	5500	3010	6686	6976	1865	1575
3-Free Mast	6000	3160	7136	7476	2065	1725
3-Free Mast	6500	3310	7586	7976	2265	1875
3-Free Mast	7000	3610	8286	8476	2365	2175

Options

ITEM	OPTIONS (optional items marked in yellow)
Fork dimension	1220mm Hook-on forks Customized fork length/non-standard accessories
Fork carriage width option	Customized fork carriage width
Backrest height	1995mm load backrest
Seat type	Upgraded suspension seat with armrest + headrest + safety seat-belt switch Grammer MSG65-531 (suspension seat with armrest + safety belt switch)
Attachments	Hook on type sideshift Hook on type fork positioner with sideshift Fork positioner with pin type forks
Battery capacity	309V228Ah LFP battery 309V304Ah LFP battery
Charger	20kw (AC 370V-460V, 50-60HZ, 32A plug) 40kw (AC 370V-460V, 50-60HZ, 63A plug)
Buzzer	Yes
Camera	Reversing radar/reversing camera/reversing radar and camera
OPS system	Yes
USB interface	USB interface 24V
Cabin	Basic half-cabin: front windshield, front wiper (including sprinkler), roof Upgrade half-cabin: basic half-cabin, rear windshield, rear wiper Basic full cabin: upgrade half-cabin, left and right doors, defogging function Upgrade full cabin: basic full cabin, air conditioner

ITEM	OPTIONS (optional items marked in yellow)
Overhead guard	Standard overhead guard
Turn speed control	Yes
Heating system during lithium battery charging	Yes
Mast lifting and lowering buffer	Yes
Mechanical lever	Yes
Rear grab handle with horn	Yes
Lighting package	LED front working light, turn signal light, market light, LED rear working light, strobe warning light LED working lights on mast Rotating warning light / rotating buzzer warning light Rear/rear and front blue lamp Front fog light Customized area warning lamp
Options	Fingertips Cigarette lighter socket 12V5A
Tyres type	Pneumatic Solid tyres / non-marking tyres
Adjustable overspeed alarm	Yes